

## Quick Start Guide & Service and Warranty Information



**XXYRON**<sup>®</sup>  
Personal Cutting System

Please fully read your instruction manual for instructions  
on proper usage, care, warnings and helpful tips.

### 1 Plug machine into electrical outlet

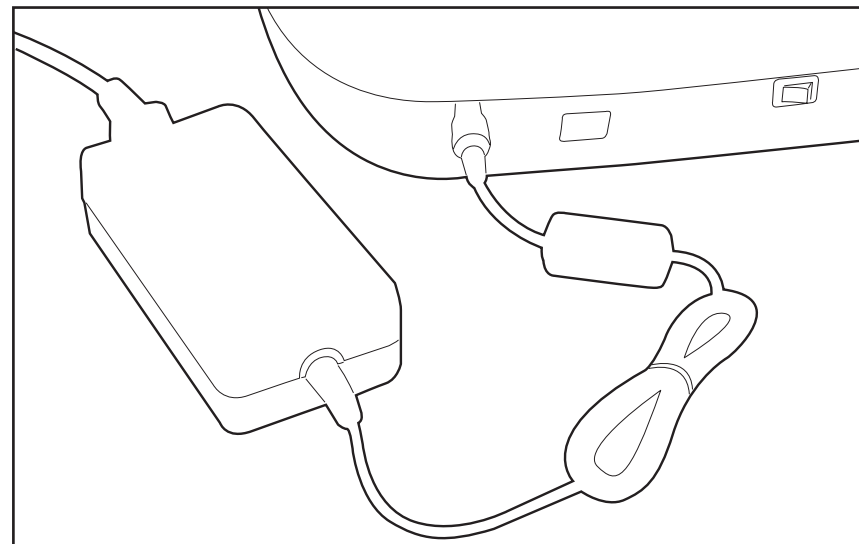

### 2 Open Design Dock and insert Design Book

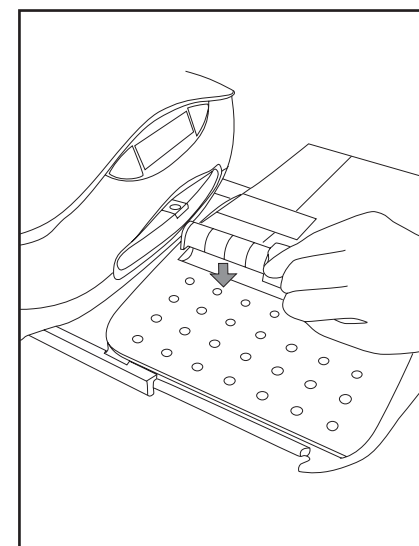
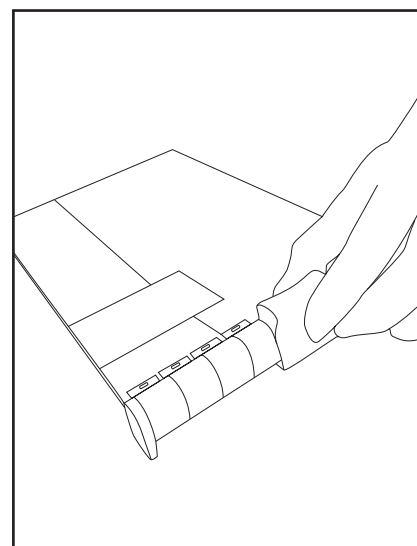

OVER PLEASE

**3 Remove Cutting Tray, replace test paper with your desired paper stock, and insert into machine.**

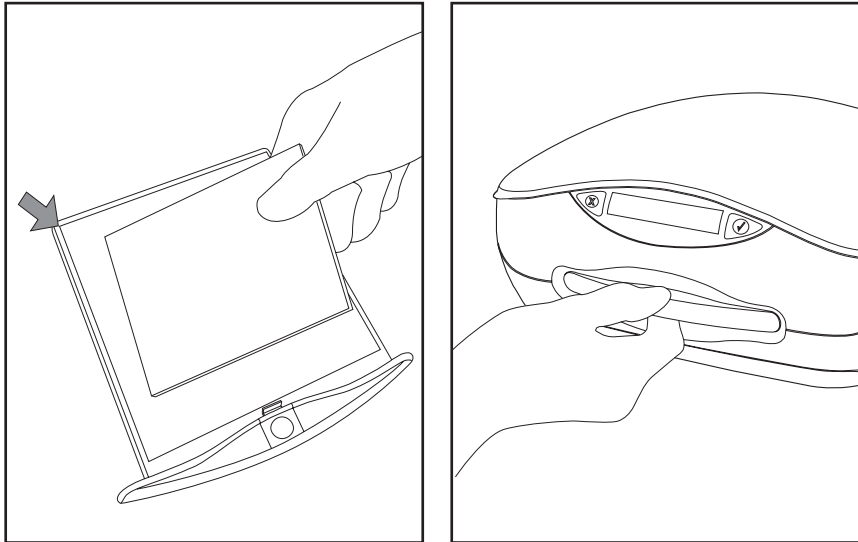

**4 Select sizes (− +) and designs, then Cut**

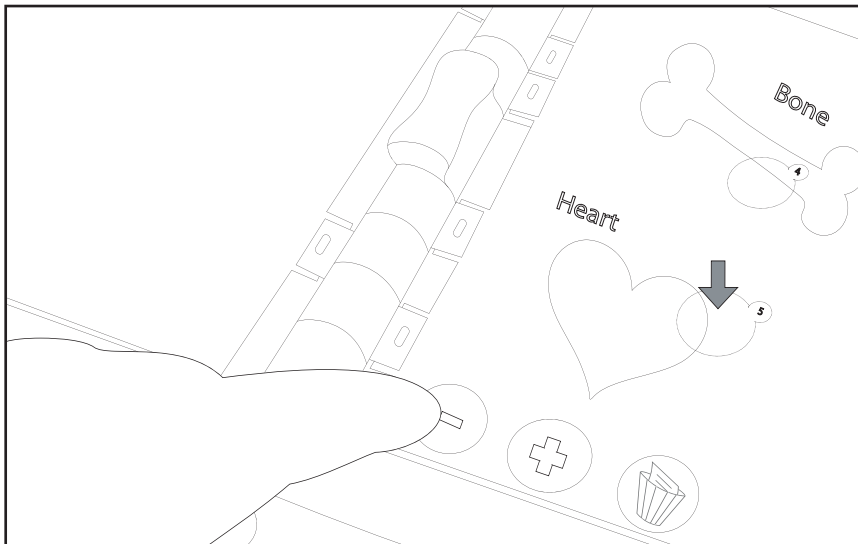

**Service & Warranty**

Dear Customer,  
Thank you for purchasing this Xyron Product, which has been designed and manufactured to the highest quality standards. If, unfortunately, something should go wrong with this product, Xyron guarantees free of charge, labor & replacement parts during a 1-year period from the purchase date.

**Warranty**

The terms of the 1-year Warranty are described below. If defective, please contact our free service desk: 1-877-392-9474.

**Xyron Customer Help Desk**

In the case your Xyron product is not working correctly, or is defective, please contact Xyron directly, at 1-877-392-9474

**IMPORTANT:**

In order to avoid unnecessary inconvenience we advise you to read the operation instructions carefully before contacting the Xyron Customer Help Desk.

**IN ORDER TO QUALIFY FOR OUR HELP DESK SERVICES WE KINDLY ASK YOU TO REGISTER YOUR PURCHASE BY COMPLETING THE POSTAGE PAID QUESTIONNAIRE.**

**TO BE RETURNED WITH THE MACHINE IF DEFECTIVE**

All Cutting Systems are sold with a 1-year Warranty. The terms of the 1 year Warranty are as follows:

1. Each machine is guaranteed against all defects in material and/or workmanship for a period of one (1) year from the date of purchase.
2. No machine will be accepted without written notification from the customer giving details of the problem that has occurred, and proof of purchase with purchase date circled and official RMA number issued only by Xyron Customer Service
3. All machines for repair are to be returned to Xyron with adequate packaging. No liability will be accepted by Xyron for goods damaged in transit from the customer, due to inadequate attention to packaging.
4. The supplier will be responsible for all parts and labor charges as necessary to repair the machine.
5. Xyron may choose to replace defective machine with a fully functional reconditioned machine, or, use reconditioned parts to repair the machine.

**The 1-year Warranty is subject to the following conditions:**

All Cutting Systems are sold with a 1-year Warranty. The terms of the 1-year Warranty are as follows:

- a. That the supplied machine has been used strictly in accordance with the operating instructions supplied with the machine.
- b. That if the benefit of this Warranty is sought, the machine must be returned, postage paid to the Xyron Authorized Repair Center. Xyron does not accept responsibility for loss or damage in transit.
- c. That the Warranty is invalid if the defects are found to be caused by accident, misuse, alteration, or neglect.
- d. That the Warranty does not cover machines used for commercial output.
- e. That the Warranty covers only the time period from the date of original purchase from a Xyron-authorized Dealer.
- f. That this Warranty does not affect your statutory rights as a consumer.

Date of Purchase:.....

Model No./Serial No.:.....

Company Name:.....

Contact Name:.....

Shipping Address:.....

Telephone/Fax No.:.....

Attach proof of purchase to this form. Send defective machine and this form to Xyron, Inc.

Personal Cutting System Warranty  
E. 7400 Tierra Buena Lane,  
Scottsdale, AZ 85260 U.S.A.