

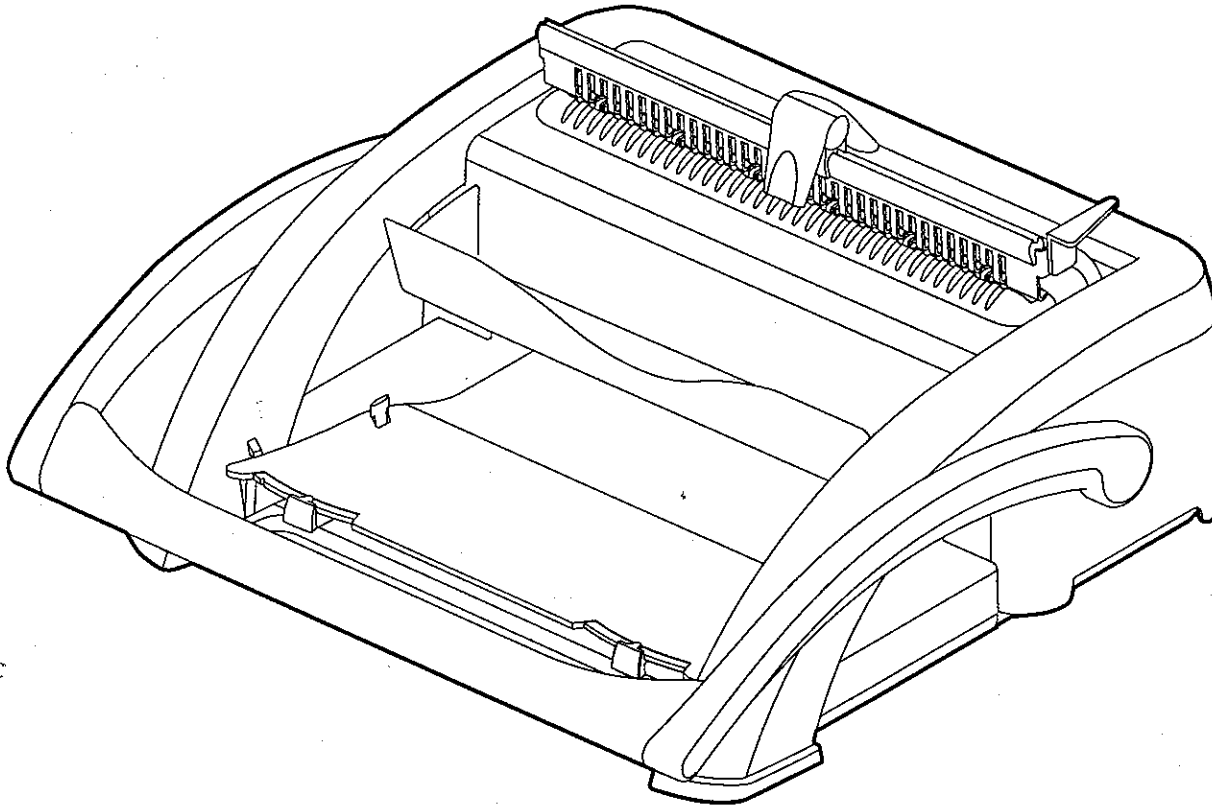

ProClick™ P200

Done



***Instruction Manual***

***E Instrucciones de Manej***

***F Manuel D'Utilisation***

**IMPORTANT**

To quickly and easily confirm your warranty, register your new Binding system at [www.GBCOffice.com](http://www.GBCOffice.com)



**Caution:** Place the binder upon a secure, stable work surface.

**Note:** Before getting started, punch several scrap sheets of paper to eliminate any residue that may be present in the punch throat area. If this is not done, your initial document may be stained.

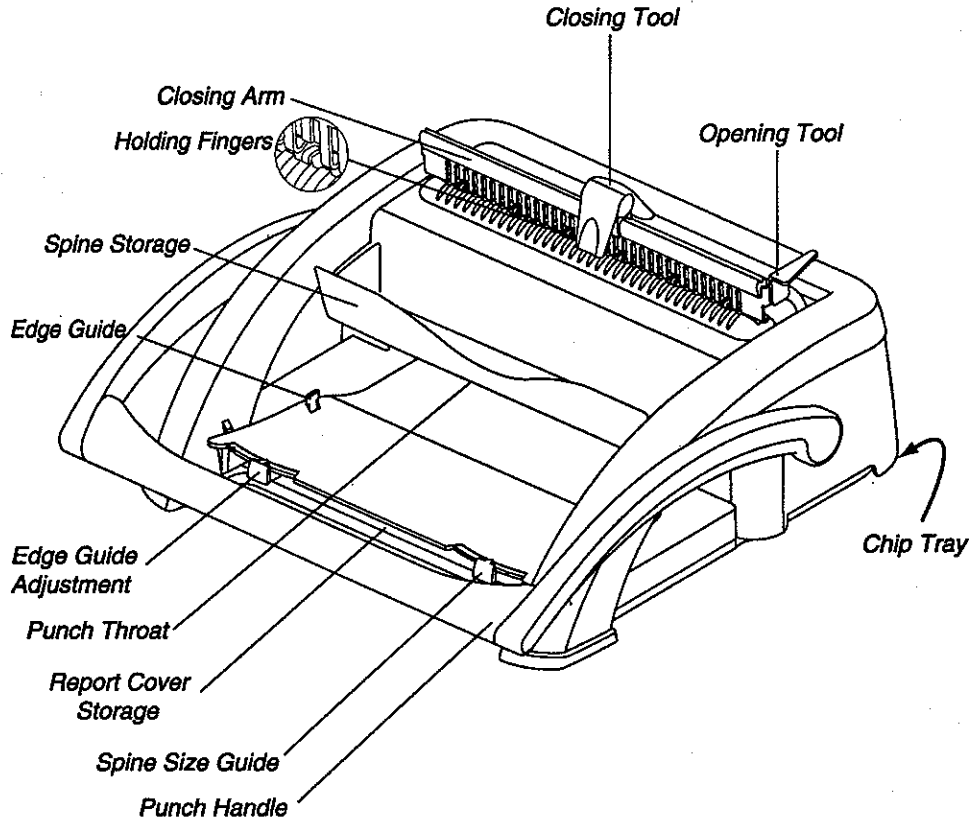

### Determining Width

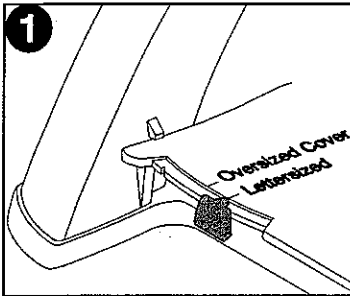

1. Set edge guide to the size paper you wish to bind, letter size (11") or over-sized covers (11 1/4").

### Punching

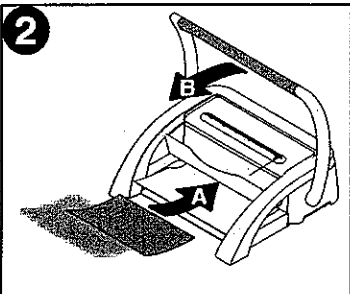

2. Align sheets or covers and insert edge to be bound into punch throat (A), document flush against edge guide and back of punch throat. To punch, push handle (B) towards the front of the machine and down.

**Note:** Punch only one plastic cover at a time to minimize jams and excessive wear.

## Determining Spine Size

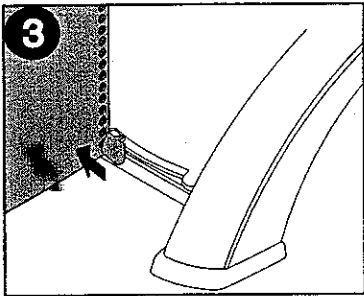

3. Place the document including covers into the spine size guide. Based upon the indicated size, use the appropriate ProClick spine.

## Binding

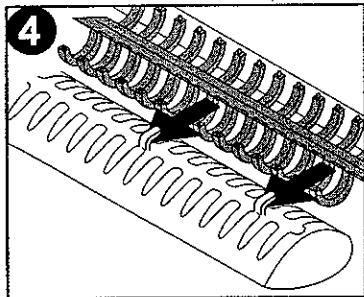

4. Raise the ProClick closing arm. Position the ProClick spine underneath the holding fingers in the top loading area.

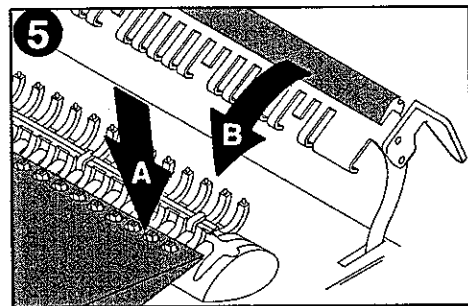

5. (A) Collate and thread the document onto the spine.

 **Tip:** For a more professional look and to conceal the spine, follow figure 5c.

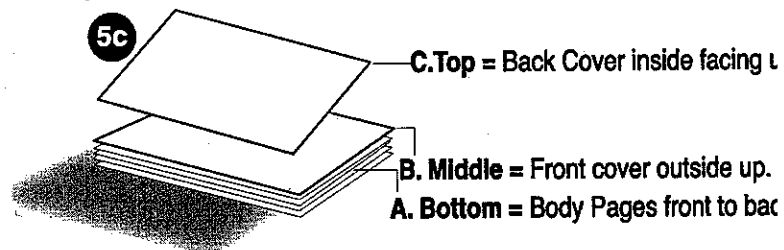

(B) Lower the ProClick closing arm and push downward to p  
compress the spine.

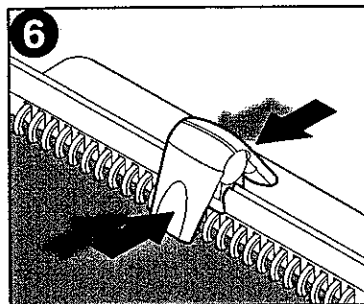

6. Squeeze the wings of the closing tool in the center of the ProClick spine.

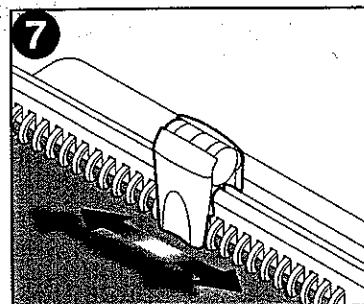

7. Slide the closing tool across left to right to completely close the spine. Raise the arm and release the document from the holding fingers.

**Note:** If you followed figure 5c, you can now reposition the back cover to complete your presentation.

## Editing

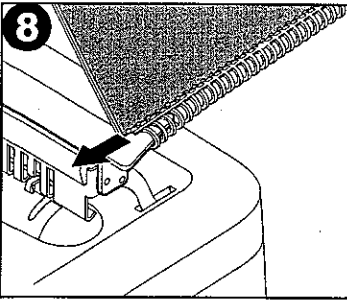

8. To reopen the spine for making edits, position the arm in the downward position. Insert the ProClick spine into the opening tool and slide towards you (the spine opening must be facing downwards).

## Storing Supplies

This binding system features report cover and ProClick spine storage to keep your supplies organized and easily accessible. Report covers can be stored below the paper tray and ProClick spines can be placed in the front bin.

## Maintaining the Machine

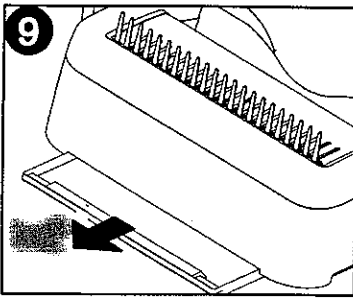

9. Empty the chip tray located on the backside of the machine after repeated use.

## Troubleshooting

Symptom	Cause	Corrective Action
Paper is punched on an angle	Paper chips blocking the throat area	Insert paper (narrow side) into the throat area and slide paper from right to left to clear blockage
	Paper not inserted fully into the throat area	Insert paper fully into the throat area until paper stops.
Difficulty punching	Chip tray is full	Empty chip tray after repeated use
	Sheet capacity is exceeded	Reduce the amount of sheets being punched.

If none of the above actions correct the problem contact your dealer or in the U.S. call GBC Customer Service at: 800.477.9900.

## Specifications

Maximum Sheet Width:	11 1/4"
Number of Punching Dies:	32
Punch Capacity:	16 sheets of 20 lb. paper
Bind Capacity:	100 sheets of 20 lb. paper
Net Weight:	14.85 lbs.
Dimensions (W x H x D):	17.5" x 14.5" x 8.5"