

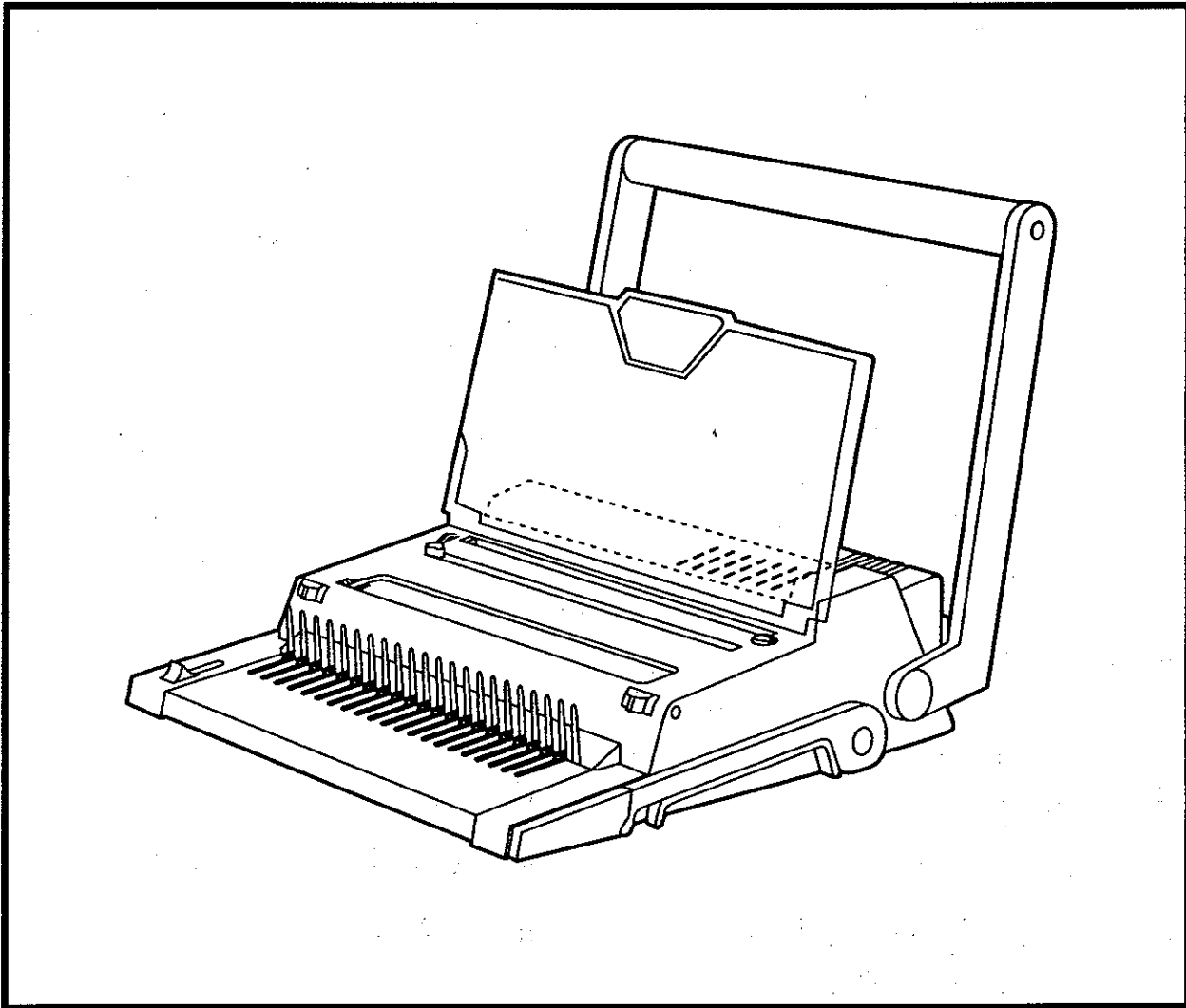

# CombBind™ C500



**Instruction Manual**  
**Manuel D'Instruction**  
**Manual de Operacion**

Register this new product on-line @ [www.GBC.com](http://www.GBC.com)

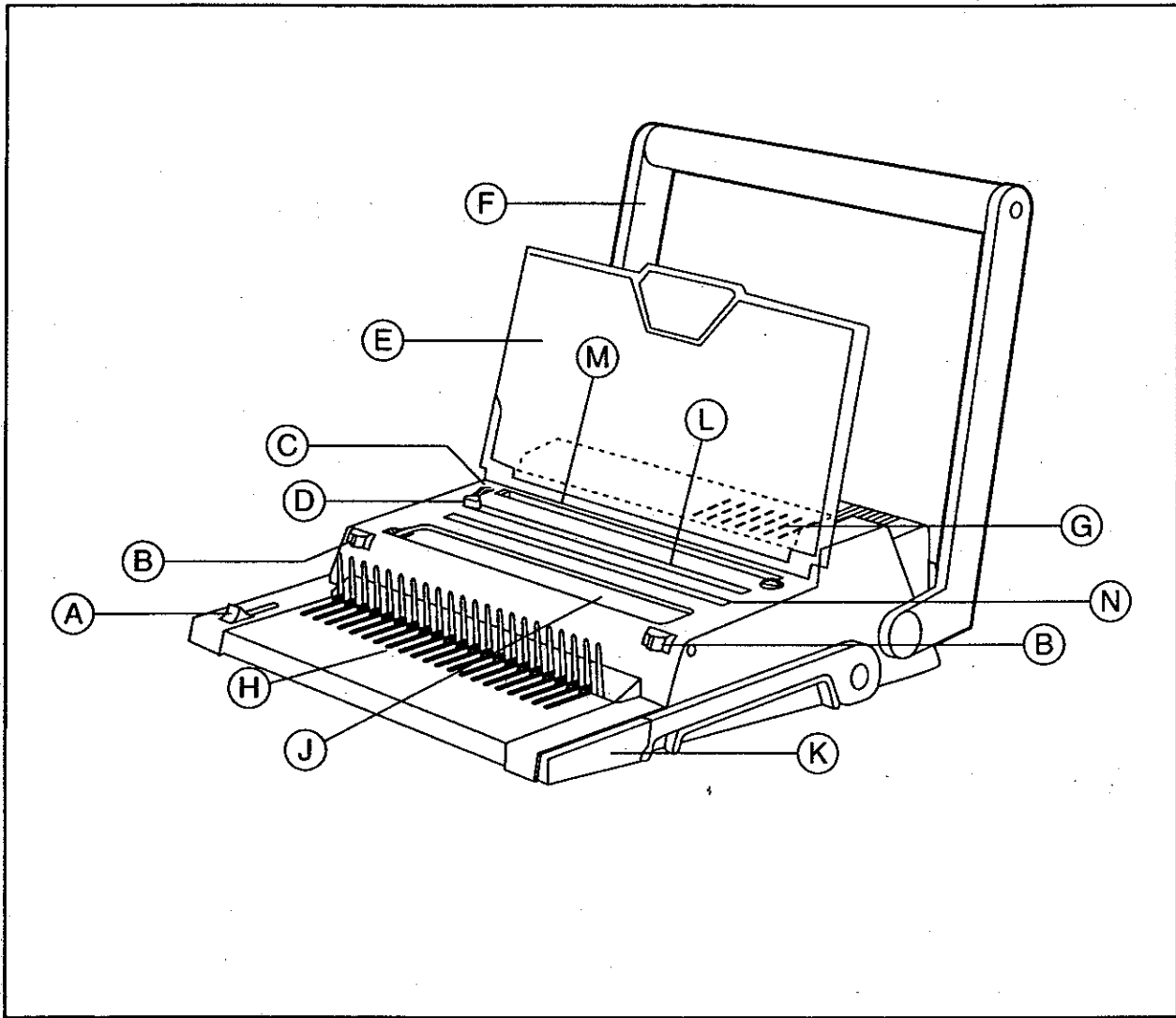

- |  |                                     |
|--|-------------------------------------|
| <b>A</b> Binding Stop Guide                                | <b>H</b> Binding Table              |
| <b>B</b> Transport Locks                                   | <b>J</b> Wire Binding Channel       |
| <b>C</b> Adjustable Side Guide<br>(for Plastic Comb)       | <b>K</b> Binding Handle             |
| <b>D</b> Adjustable Side Guide<br>(for Twin Loop Wire)     | <b>L</b> Wire Punch Channel         |
| <b>E</b> Lid/Document Support                              | <b>M</b> Plastic Comb Punch Channel |
| <b>F</b> Punching Handle                                   | <b>N</b> Wire Holder                |
| <b>G</b> Disengageable Punching Dies<br>(for Plastic Comb) |                                     |

**IMPORTANT:** Please read through these operating instructions carefully and keep them in a safe place for future reference.

Thank you for purchasing the CombBind C500 punching and binding systems. If used properly, your machine will be virtually maintenance-free and provide years of service.

**⚠ CAUTION**

Your binding machine was developed exclusively for punching and binding paper and plastic covers. Only use the machine for this purpose to ensure a long service life.

Take care when binding with wire combs that your fingers do not get caught in the binding channel (danger of fingers being crushed)!

The punching dies were oiled in production to keep them free from corrosion and to ensure that the parts move easily. Before using, punch scrap paper several times to remove all traces of oil from the dies.

**GENERAL SAFEGUARDS**

- Use the CombBind C500 only for its intended purpose of a punching and binding paper and covers according to the indicated specifications.
- Do not place anything in the punch opening of the machine other than paper and cover stock.
- Place unit on a secure, stable work area to prevent the machine falling and possibly causing personal injury and damage to the unit.
- Follow all warnings and instructions marked on the product.
- Lift the machine from the bottom, not the cover.

**PREPARING THE MACHINE**

1. Place the machine on a sturdy surface.
2. Lift the document lid (E).
3. Unlock the Transport Locks (B) on both sides and push the Punching Handle (F) up.

---

**PUNCHING PLASTIC**

1. Lift lid (E) and Punching Handle (F).
2. Adjust the Side Guide (C) for the paper size being used.
3. Place sheets or covers in the plastic comb punching channel (M).
4. Disengage last two punching dies (G) for letter-size documents. NOTE: The dies can only engage and disengage when the binding lever is in a vertical position.
5. Press the Punching Handle (F) down.
6. Lift Punching Handle (F) and remove the punched document.

**PUNCHING WIRE**

1. Lift lid (E) and Punching Handle (F).
2. Adjust the Side Guide (D) for the paper size being used.
3. Place sheets or covers in the wire punching channel (N).
4. Press the Punching Handle (F) down.
5. Lift Punching Handle (F) and remove the punched document.

## BINDING WITH PLASTIC COMBS

1. Choose a plastic comb that is approximately 1/8" longer than the thickness of your document to be bound.
2. Insert the binding comb behind the fingers of the Binding Table (H) open edge facing up.
3. Lift Binding Handle (K). Once lifted, it will release and move to the right.
4. Lower the Binding Handle (K) to open the comb.
5. Set Binding Stop Guide (A) if you wish to bind multiple documents of the same diameter. As the two handles for punching and binding do not obstruct each other, you can punch all other sheets of your document and place them into the opened comb.
6. Place punched sheets and covers face downward onto plastic comb fingers.
7. Lift the Binding Handle (L) and remove bound document.

## BINDING WITH TWIN LOOP WIRE

1. Choose a wire element that has the appropriate sheet capacity for your document to be bound.
2. Place the front and rear covers of your book back-to-back on top of the front cover so that the wire opening will be hidden inside the rear cover after binding.
3. Slide the Wire Binding Stop Guide (A) to the correct diameter and let it click into place.
4. Insert the wire comb through the punched holes as shown in figure, or use the Wire Holder (N) to secure the wire while you place sheets into it.

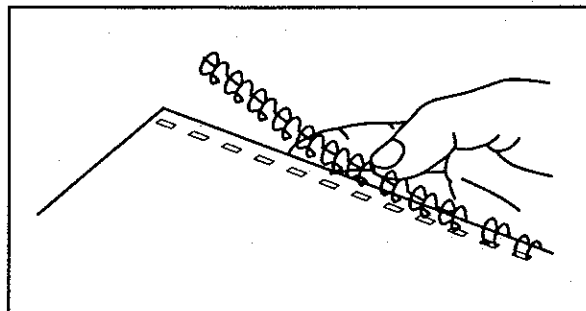

Figure 1

5. Use your left hand to hold the document and insert into the Wire Comb Binding Channel (J) with the open end of the comb facing downward.
6. Use your right hand to lower the Binding Handle (K) far enough to close the wire comb.

## EMPTYING THE WASTE TRAY

1. Lower the Punching Handle (F), lock the two Transport Locks (B) and Lower Lid (E).
2. Set the machine in an upright position.
3. Pull open the tray on the bottom of the machine, empty it and replace.

## TRANSPORTING OR STORING THE MACHINE

1. Lower the Punching Handle (F), lock the two Transport Locks (B) and Lower Lid (E).
2. Lift machine by punching handle to transport or store it in a horizontal or vertical position.

## SERVICE

Should your CombBind C500 require service contact:

**GBC** | Commercial &  
Consumer Group  
Skokie, IL 60077  
www.GBC.com

## SPECIFICATIONS

Dimensions:	5" (H) x 16 3/4" (W) x 16 3/4" (D)	Paper Stop:	Adjustable, lockable
Max. width of sheets to be bound	11.5" (297 mm)	Punching Depth:	Fixed
Number of Punching Dies	21 (7 are disengageable)	Max. diameter of binder, plastic	2" (51 mm)
Sheet Capacity: (paper sheets)	Max. 20 sheets (20 lb.)	Max. diameter of binder, wire	1/2" (14 mm)
Punching Capacity: (plastic covers)	2 covers	Net weight	25.5 lbs. (11.5 Kg)